

General Description

Manual No.	150400048A
Manual Version	V1.0
Date	May, 2016

Thanks for purchasing HCFA products.



This manual describes the specifications of TP(TL)2510-(E) , TP(TL)2507-(E) , TP(TL)2504-(E) (hereinafter referred to as TP). Before use, read this manual and manuals of relevant products fully to acquire proficiency in handling and operating the product. Make sure to learn all the product information, safety information, and precautions.

Effective May, 2016
Specifications are subject to change without notice.

© HCFA Corporation Ltd

Safety Precaution (Read these precautions before using.)

Before using this product, please read this manual and the relevant manuals introduced in this manual carefully and pay full attention to safety to handle the product correctly. The precautions given in this manual are concerned with this product. In this manual, the safety precautions are ranked as "WARNING" and "CAUTION".

 WARNING	Indicates that incorrect handling may cause hazardous conditions, resulting in death or severe injury.
 CAUTION	Indicates that incorrect handling may cause hazardous conditions, resulting in medium or slight personal injury or physical damage.

Depending on circumstances, procedures indicated by "CAUTION" may also be linked to serious results. In any case, it is important to follow the directions for usage.

DESIGN PRECAUTIONS

- Some failures of the TP or cable may keep the outputs on or off. An external monitoring circuit should be provided to check for output signals which may lead to a serious accident. Not doing so can cause an accident due to false output or malfunction.
- Do not use the TP as the warning device that may cause a serious accident. An independent and redundant hardware or mechanical interlock is required to configure the device that displays and outputs serious warning. Failure to observe this instruction may result in an accident due to incorrect output or malfunction.
- When the TP detects its backlight failure, the TP disables the input operation on the touch switches. Thus, operators cannot operate the TP with touches. The TP backlight failure can be checked with a system signal of the TP.
- Even when the display section has dimmed due to a failure of liquid crystal section or backlight on the TP, the input operation of touch switches may still be enabled. This may cause an incorrect operation of touch switches. For example, if an operator assumes that the display section has dimmed because of screen save function and touches the display section to cancel screen save, a touch switch may be activated. The TP backlight failure can be checked with a system signal of the TP.
- The display section of TP is an analog-resistive type touch panel. Simultaneous pressing of two or more areas on the display section may activate the switch between those areas. Do not press two or more areas simultaneously on the display section. Doing so may cause an accident due to incorrect output or malfunction.
- When the programs and parameters of controller (such as a PLC) that is monitored by a TP are changed, be sure to shut off the power of the TP promptly and power on the TP again. Not doing so can cause an accident due to false output or malfunction.
- If a communication fault (including cable disconnection) occurs during monitoring on the TP, communication between the TP and PLC CPU is suspended and the TP becomes inoperative. A system where the TP is used should be configured to perform any significant operation to the system by using the switches of a device other than the TP on the assumption that a TP communication fault will occur. Not doing so can cause an accident due to false output or malfunction.

DESIGN PRECAUTIONS

- Do not bundle the control and communication cables with main-circuit, power or other wiring. Run the above cables separately from such wiring and keep them a minimum of 100mm (3.94in.) apart. Not doing so noise can cause a malfunction.
- Do not press the TP display section with a pointed material as a pen or driver. Doing so can result in a damage or failure of the display section.
- When the TP is connected to Ethernet network, the available IP address is restricted according to the system configuration.
 - When multiple TPs are connected to the Ethernet network: Do not set the IP address (192.168.0.200) for the TPs and controllers in the network.
 - When a single TP is connected to the Ethernet network: Do not set the IP address (192.168.0.200) for the controllers except the TP in the network.
- Doing so can cause the IP address duplication. The duplication can negatively affect the communication of the device with the IP address (192.168.0.200). The operation of IP address duplication depends on the devices and system.
- Turn on the controller and network device to be ready for communication before they communicate with the TP. Failure to do so can cause a communication error on the TP.
- When the TP is subject to shock and vibration, or some color appear on the screen of the TP, the screen of TP might flicker.

MOUNTING PRECAUTIONS

- Be sure to shut off all phases of the external power supply used by the system before mounting or removing the TP to/from the panel. Not doing so can cause the unit to fail or malfunction.

MOUNTING PRECAUTIONS

- Use the TP in the environment that satisfies the general specifications described in this manual. Not doing so can cause an electric shock, fire, malfunction or product damage or deterioration.
- When mounting the TP to the control panel, tighten the mounting screws in the specified torque range (0.36N·m to 0.48 N·m). Undertightening can cause the TP to drop, short circuit or malfunction. Overtightening can cause a drop, short circuit or malfunction due to the damage of the screws or the TP.
- Remove the protective film of the TP. When the user continues using the TP with the protective film, the film may not be removed.
- Operate and store the TP in environment without direct sunlight, high temperature, dust, humidity and vibration.
- Do not use the TP in an environment with oil or chemical. Doing so can cause failure or malfunction due to the oil or chemical entering into the TP.

WIRING PRECAUTIONS

- Be sure to shut off all phases of the external power supply used by the system before wiring. Failure to do so may result in an electric shock, product damage or malfunctions.

WIRING PRECAUTIONS

- Please make sure to ground FG terminal of the TP power supply section. Not doing so may cause an electric shock or malfunction.
- Correctly wire the TP power supply section after confirming the rated voltage and terminal arrangement of the product. Not doing so can cause a fire or failure.
- Tighten the terminal screws of the TP power supply section in the specified torque range (0.5N·m to 0.6 N·m). Undertightening can cause a short circuit or malfunction. Overtightening can cause a short circuit or malfunction due to the damage of the screws or the TP.
- Ensure to avoid foreign matter such as chips and wire offcuts entering the TP. Not doing so can cause a fire, failure or malfunction.
- Plug the communication cable into the TP interface or the connector of the connected unit, and tighten the mounting screws and the terminal screws in the specified torque range. Undertightening can cause a short circuit or malfunction. Overtightening can cause a short circuit or malfunction due to the damage of the screws or the TP.

TEST OPERATION PRECAUTIONS

- Before performing the test operation of the user creation monitor screen (such as turning ON or OFF bit device, changing the word device current value, changing the settings or current values of the timer or counter), read through the manual carefully and make yourself familiar with the operation method. During test operation, never change the data of the devices which are used to perform significant operation for the system. False output or malfunction can cause an accident.

STARTUP/MAINTENANCE PRECAUTIONS

- When power is on, do not touch the terminals. Doing so can cause an electric shock or malfunction.
- Before starting cleaning or terminal screw retightening, always switch off the power externally in all phases. Not switching the power off in all phases can cause a unit failure or malfunction. Undertightening can cause a short circuit or malfunction. Overtightening can cause a short circuit or malfunction due to the damage of the screws or unit.

STARTUP/MAINTENANCE PRECAUTIONS

- Do not disassemble or modify the unit. Doing so can cause a failure, malfunction, injury or fire.
- Do not touch the conductive and electronic parts of the unit directly. Doing so can cause a unit malfunction or failure.
- The cables connected to the unit must be run in ducts or clamped. Not doing so can cause the unit or cable to be damaged due to the dangling, motion or accidental pulling of the cables or can cause a malfunction due to a cable connection fault.
- When unplugging the cable connected to the unit, do not hold and pull the cable portion. Doing so can cause the unit or cable to be damaged or can cause a malfunction due to a cable connection fault.
- Do not drop or apply any impact to the battery. If any impact has been applied, discard the battery and never use it. The battery may be damaged by the drop or impact.
- Before touching the unit, always touch grounded metal, etc. to discharge static electricity from human body, etc. Not doing so can cause the unit to fail malfunction.

TOUCH PANEL PRECAUTIONS

- For the analog-resistive film type touch panel, normally the adjustment is not required. However, the difference between a touched position and the object position may occur as the period of use elapses. When any difference between a touched position and the object position occurs, execute the touch panel calibration.
- When any differences between a touched position and the object position occurs, other object may be activated. This may cause unexpected operation due to incorrect output or malfunction.

PRECAUTIONS WHEN THE DATA STORAGE IS IN USE

- If the SD card mounted on the drive A of the TP is removed while the TP is accessed, processing for the TP might be interrupted for about 20 seconds. The TP cannot be operated during this period. The functions that run in the background including a screen updating, alarm, logging, scripts and other are interrupted. Since this interruption makes an impact to the system operation, it might cause failure. After inhibiting the access to SD card on the TP utility screen, check that the SD card access LED is off and remove the SD card.

PRECAUTIONS WHEN THE DATA STORAGE IS IN USE

- If the data storage mounted on the TP is removed while the TP is accessed, the data storage and files are damaged. To remove the data storage from the TP, check that the access to data storage in SD card access LED, the system signal and others are not performed.
- When removing SD card from the TP, make sure to support the SD card by hand as it may pop out. Failure to do so may cause the SD card to drop from the TP, resulting in a failure or break.
- Before removing USB device from the TP, follow the procedure for removal on the utility screen of the TP. After the successful completion dialog is displayed, remove the USB device by hand carefully. Failure to do so may cause the USB device to drop from the TP, resulting in a failure or break.

DISPOSAL PRECAUTIONS

- When disposing this product, treat it as industrial waste.

TRANSPORTATION PRECAUTIONS

- Before transporting the TP, turn the TP power on and check that the battery voltage status is normal on the Time setting & display screen (utilities screen). In addition, confirm that the adequate battery life remains on the rating plate. Transporting the TP with the low battery voltage or the battery the reached battery life may destabilize the backup data unstable during transportation.
- Make sure to transport the TP main unit and/or relevant unit(s) in the manner they will not be exposed to the impact exceeding the impact resistance described in the general specifications of this manual, as they are precision devices. Failure to do so may cause the unit to fail. Check if the unit operates correctly after transportation.

Associated Manuals (For the details of a PLC to be connected, refer to the PLC user' s manual respectively.)

Bundled items

Model name	Specification
TP(TL)2510-(E)	10" [800×480 dots], TFT color, 24 bit color, 24VDC, Memory size 128MB, built-in Ethernet interface
TP(TL)2507-(E)	7" [800×480 dots], TFT color, 24 bit color, 24VDC, Memory size 128MB, built-in Ethernet interface
TP(TL)2504-(E)	4.3" [480×272 dots], TFT color, 24 bit color, 24VDC, Memory size 128MB, built-in Ethernet interface

Model name	Bundled items	Quantity
TP(TL)2510-(E) TP(TL)2507-(E)	Mounting fitting	4
	TP25 General Description (this manual)	1
	TP16-PLC-R4-8P-3M	1
TP(TL)2504-(E)	Mounting fitting	4
	TP25 General Description (this manual)	1
	TP16-PLC-R4-8P-3M-elbow	1

1. Product overview

1.1 TP(TL)2510-(E) Parts name and external dimension

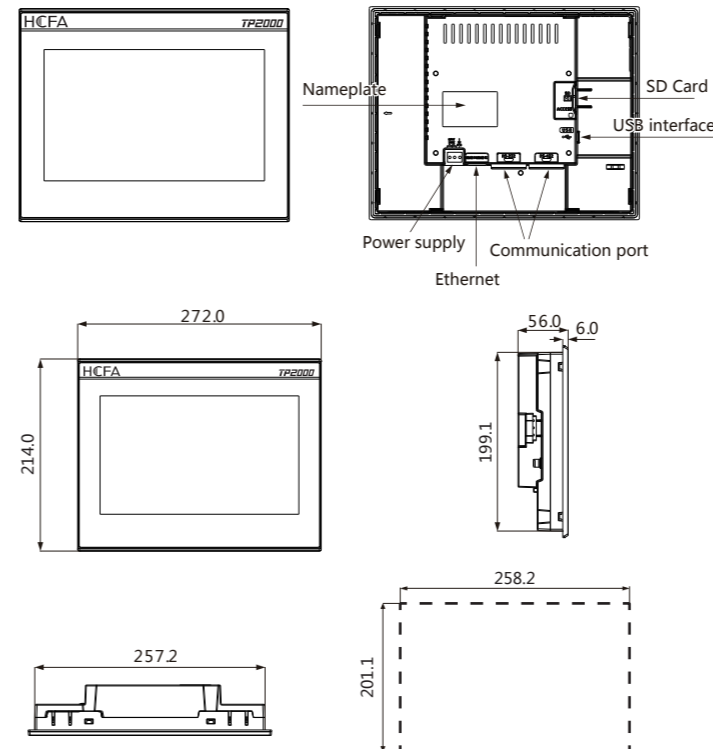

1.2 TP(TL)2507-(E) Parts name and external dimension

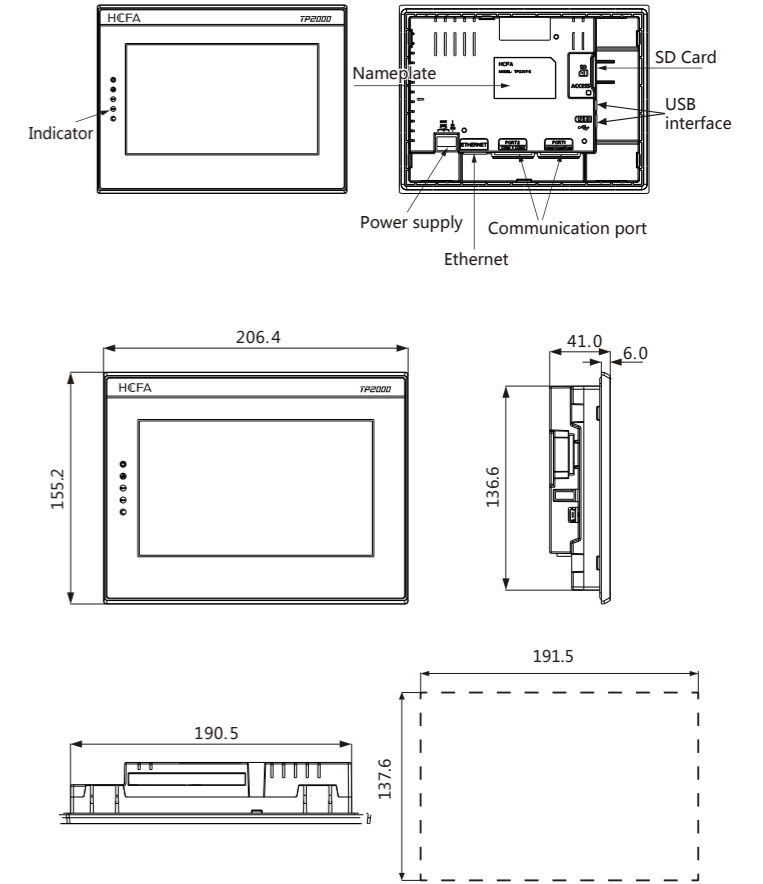

1.3 TP(TL)2504-(E) Parts name and external dimension

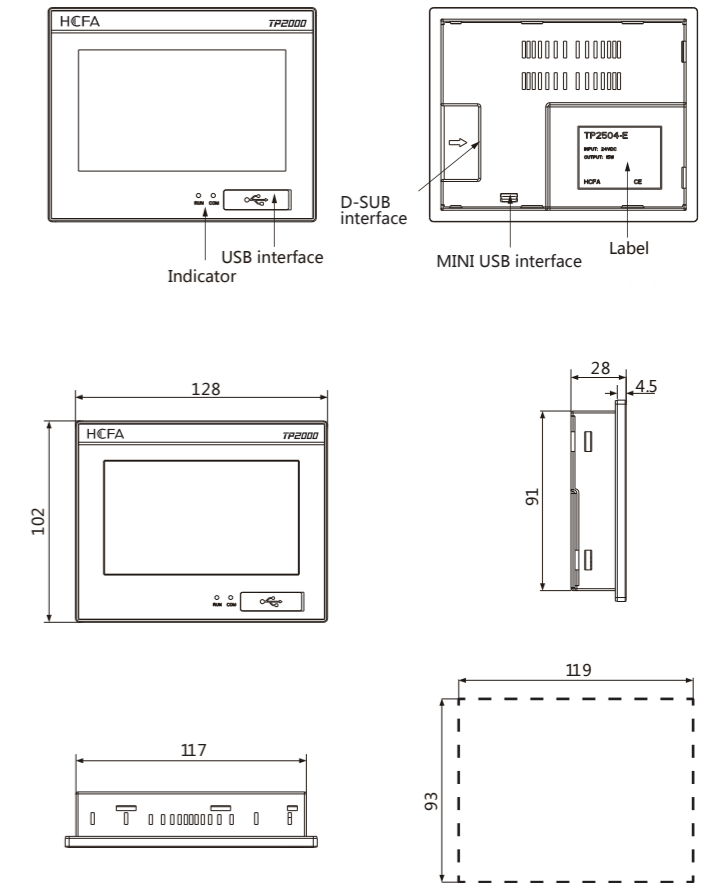

2. Specifications

2.1 General specifications

Item	Specifications					
Operating ambient temperature	0 ~ 50°C					
Storage ambient temperature	-20 ~ 60°C					
Operating/storage ambient humidity	10 to 90% RH, non-condensing (The wet bulb temperature is 39°C or less.) When the ambient temperature exceeds 40°C, maintain the absolute humidity at 40°C and 90%					
Vibration resistance	Conform to IEC 61131-2	Under intermittent vibration	Frequency	Acceleration	Half-amplitude	Sweep count
			5 ~ 8.4Hz	—	3.5mm	
		Under continuous vibration	5 ~ 8.4Hz	9.8m/s ²	—	10 times each in X,Y and Z directions
			8.4 ~ 150Hz	—	1.75mm	
Shock resistance	Conforms to IEC 61131-2 (147m/s ² , 11 ms, 3 times each in the X, Y, and Z directions.)					
Operating atmosphere	Must be free of lamp black, corrosive gas, flammable gas, or excessive amount of electroconductive dust particles and must be no direct sunlight. (Same as for saving)					
Operating altitude *1	2000m (6562 ft) max.					
Installation location	Inside control panel					
Overvoltage category*2	II or less					
Pollution degree*3	2 or less					
Cooling method	Self-cooling					
Grounding	Class D grounding (100Ω or less). To be connected to the panel when the grounding is not possible.					

*1 Do not use or store the TP under pressure higher than the atmospheric pressure of altitude 0m. Failure to observe this instruction may cause a malfunction. When the air inside the control panel is purged by pressurization, the surface sheet may be lifted by higher pressure. As a result, the touch panel may be difficult to press, and the sheet may be peeled off.

*2 This indicates the section of the power supply to which the equipment is assumed to be connected between the public electrical power distribution network and the machinery within the premises. Category II applies to equipment for which electrical power is supplied from fixed facilities. The surge voltage withstand level for up to the rated voltage of 300 V is 2500 V.

*3 This index indicates the degree to which conductive material is generated in the environment where the equipment is used. In pollution degree 2, only non-conductive pollution occurs but temporary conductivity may be produced due to condensation.

2.2 Performance specifications

Item	Specifications			
	TP(TL)2510-(E)*1	TP(TL)2507-(E)	TP(TL)2504-(E)	
Display section *2	Type	TFT color liquid crystal display		
	Screen size	10"	7"	4.3"
	Resolution	800×480 [dots]		
	Display size	W222(8.74) ×H132.5(5.22) [mm](inch) (Horizontal format)	W154(6.06) ×H85.9(3.38) [mm](inch) (Horizontal format)	W95.04(3.74) ×H53.86(2.12)[mm] (inch) (Horizontal format)
	Display character	16-dot standard font: 50 characters × 30 lines (Horizontal format)		
	Display color	24 bit color		
	Brightness	Multiple level adjustment		
	Backlight	LED-type (No replacement required) Backlight OFF/ screen saving time can be set.		
Touch panel *3	Type	Analog-resistive film type		
	Key size	Minimum 2 × 2 [dots] (per key)		
	Number of points touched simultaneously	Simultaneous 2-point presses prohibited (Only one point can be touched)		
Life	1 million times (Operating force 0.98N max.)			
Memory	C drive	128M Flash + 128M DDR3		
Built-in interface	RS-485-4W RS-485-2W	COM1	RS-485, 1ch Transmission speed: 115200/ 57600/ 38400/ 19200/ 9600/ 4800bps Connector shape: D-Sub 9pins (Male) Application: For communication with controllers Terminating resistor: External setting	
		COM2		
	RS-232	COM1	RS-232, 1ch Transmission speed: 115200/ 57600/ 38400/ 19200/ 9600/ 4800bps Connector shape: D-Sub 9pins (Male) Application: For communication with controllers	
		COM2		
		COM3		
Ethernet*4	Data transfer method: 100BASE-TX, 10BASE-T, 1ch Connector shape: RJ-45 (modular jack) Application: Support MODBUS TCP Server For PC connection(Project data upload/ download)			
USB	USB (full speed, 12Mbps) standard, 1ch Connector shape: Mini-B For application: For PC connection(Project data upload/ download)			
SD card *5	Conform to the SD standard, 1ch Supported memory card: SDHC memory card, SD card For application: Project data upload/ download		Not provided.	
Buzzer output	Single tone (Long/ short/ off adjustable)			
Protective structure*6	IP65F (only the front part of the panel)			
External dimensions	W272(10.71) ×H214(8.43) ×D56 (2.21)[mm](inch)	W206(8.11) ×H155(6.11) ×D50(1.97)[mm](inch)	W128(5.04) ×H102(4.01) ×D28(1.10)[mm] (inch)	
Panel cutting dimensions	W258(10.16) ×H200(7.88) [mm](inch) (Horizontal format)	W191(7.52) ×H137(5.40) [mm](inch) (Horizontal format)	W119(4.69) ×H93(3.66)[mm] (inch) (Horizontal format)	
Weight	Approx.1.3kg(excluding mounting fixture)	Approx.0.9kg(excluding mounting fixture)	Approx.0.26kg(excluding mounting fixture)	

*1 TP series are standard configuration models. TL series are more lowcost.

*2 Bright dots(always lit) and dark dots (unit) may appear on a LCD panel. It is impossible to avoid this symptom, as the liquid crystal display comprises of a great number of display elements. Flickers and partial discoloration may be generated on the liquid crystal display panel due to individual differences of panel. Please note that these phenomena appear due to its characteristics and are not caused by product effect.

*3 The touch panel is an analog-resistive type. Simultaneous pressing of two or more areas on the panel may activate the switch between those areas. Do not press two or more areas on the panel simultaneously.

*4 Only for "E" models.

*5 TL models do not support SD card, TP models supporting SD card.

*6 Note that this does not guarantee all users' operation environment. In addition, the product may not be used in environments under exposition of oil or chemicals for a long-period time, or in environments filled with oil-mist

2.3 Communication port

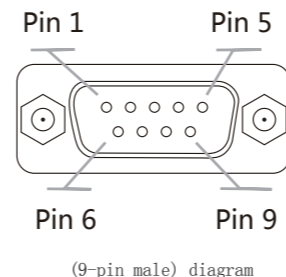

COM1/COM3 Communication port (9-pin male)	
Pin1	Rx-(B)
Pin2	RxD_PLC (COM1 RS232)
Pin3	TxD_PLC (COM1 RS232)
Pin4	Tx-
Pin5	GND
Pin6	Rx+(A)
Pin7	RxD_PC/PLC (COM3 RS232)
Pin8	TxD_PC/PLC (COM3 RS232)
Pin9	Tx+

COM2/COM4 Communication port (9-pin male)	
Pin1	Rx-(B)
Pin2	RxD_PLC (COM2 RS232)
Pin3	TxD_PLC (COM2 RS232)
Pin4	Tx-
Pin5	GND
Pin6	Rx+(A)
Pin7	RxD_PC/PLC (COM4 RS232)
Pin8	TxD_PC/PLC (COM4 RS232)
Pin9	Tx+

Note: Three models apply to COM1/COM3 communication port. However, TP(TL)2504-(E) does not apply to COM2/COM4 communication port.

2.4 Power specifications

Item	Specifications		
	TP(TL)2510-(E)	TP(TL)2507-(E)	TP(TL)2504-(E)
Input power supply voltage	24VDC (+10% -15%), ripple voltage 200mV or less		
Power consumption	10W or less		
	At backlight off	5W or less	5W or less
Inrush current	17A or less (6ms, 25°C, at max. load)		
Permissible instantaneous power failure time	Within 5ms		
Noise immunity	Conforms to IEC61000-4-4, 2kV (power supply line)		
Dielectric withstand voltage	350VAC for one minute (across power supply terminals and earth)		
Insulation resistance	500VDC across power terminals and earth, 10MΩ or more by an insulation resistance tester		

3. Communication cable connection example

1) 、 Take the communication cable of RS485-4 interface for TP2507-E and 8PIN RS422 interface for HCFA LX1S, LX1N, HCA1 , HCA2 , HCA8 as example.

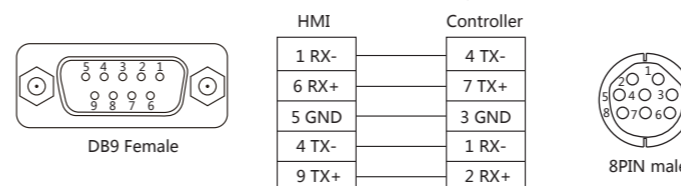

2) 、 HCFA PLC communication port RS485-2 cable DB9 Female

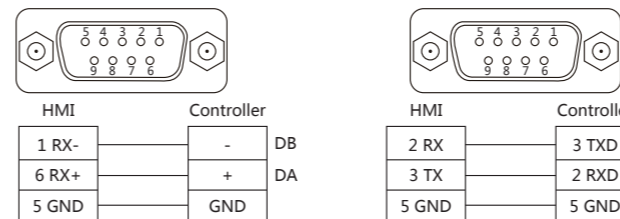

4. Product naming rule

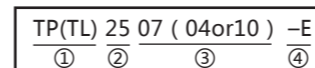

① "TP" : Prefix of HCFA HMI, abbreviation of touch panel.

TP series are standard configuration models. TL series are more lowcost.

② "25" is the series number of touch panel, which belongs to TP2000 series.

③ "07 (04 or 10)" is the screen size code. 04 represents 4.3" LCD panel, that is TP2504-E. 07 represents 7" LCD panel, that is TP2507-E. 10 represents 10" LCD panel, that is TP2510-E.

④ "-E" : The main unit is built in Ethernet function.

4.1 Model name and function configuration description

Parameter	TL2507 TL2510	TP2507 TP2510	TP2507-E TP2510-E
Color display	24-bit	24-bit	24-bit
Built-in Ethernet	X	X	√
Built-in SD card	X	√	√
USB HOST	√	√	√
USB DEVICE	√	√	√
COM1/COM3	√	√	√
COM2/COM4	X	√	√
Isolated power supply	Non-isolated power Surge protection	Non-isolated power Surge protection	Non-isolated power Surge protection

Note: The configuration of TP2504-E is different from the above. There is no SD card and COM2/COM4 in the standard configuration. And the power is non-isolated.

5. Notification of CE marking

The following products have shown compliance through direct testing (to the identified standards) and design analysis (forming a technical construction file) to the European Directive for Electromagnetic Compatibility (2004/108/EC) when used as directed by the appropriate documentation.

- This product is designed for use in industrial applications.
- Manufactured by: Zhejiang Hechuan Technology Co., Ltd
- Manufactured at: No.9, Fucai Road, Longyou industrial zone, Quzhou city, Zhejiang province, PRC
- Type: Graphic operation terminal
- Model: TP2000 series

Standard	Remark	
EN61131-2 : 2007 Programmable controllers- Equipment, requirement and tests	EMI	Compliance with all relevant aspects of the standard. (Radiated Emissions)
	EMS	Compliance with all relevant aspects of the standard. (ESD,RF electromagnetic field, EFTB, Surge, RF conducted disturbances and Power frequency magnetic field)

For more details, please contact HCFA distributor.

Website: <http://www.hechuanplc.net/>

This manual confers no industrial property rights or any rights of any other kind, nor does it confer any patent licenses. HCFA cannot be held responsible for any problems involving industrial property rights which may occur as a result of using the contents noted in this manual.

Warranty

HCFA will not be held liable for damage caused by factors found not to be the cause of HCFA; opportunity loss or lost profits caused by faults in the HCFA products; damage, secondary damage, accident compensation caused by special factors unpredictable by HCFA; damages to products other than HCFA products; and to other duties.

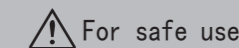

For safe use

This product has been manufactured as a general-purpose part for general industries, and has not been designed or manufactured to be incorporated in a device or system used in purposes related to human life. Before using the product for special purposes such as nuclear power, electric power, aerospace, medicine or passenger movement vehicles, consult with HCFA. This product has been manufactured under strict quality control. However when installing the product where major accidents or losses could occur if the product fails, install appropriate backup or failsafe functions in the system.



Zhejiang Hechuan Technology Co., Ltd
Address: No.9, Fucai Road, Longyou industrial zone,
Quzhou city, Zhejiang province, PRC
Phone: 0570-7117888 (Switchboard)
Fax: 0570-7882868
Website: <http://www.hechuanplc.net/>
E-mail: hechuan@hcfa.cn